

- NOTE:
1. FLARED END TO SUIT PIPE (CSP OR CONCRETE)
 2. RIP RAP TO BE HAND PLACED - 150mm MIN. DIA.
 3. RIP RAP SHALL BE HAND PLACED ROCK COBBLE OR BAGGED CONCRETE AS SPECIFIED BY THE ENGINEER.
 4. THICKNESS 300mm (D SMALLER THAN 1400mm)
THICKNESS 600mm (D=1400-2000mm)

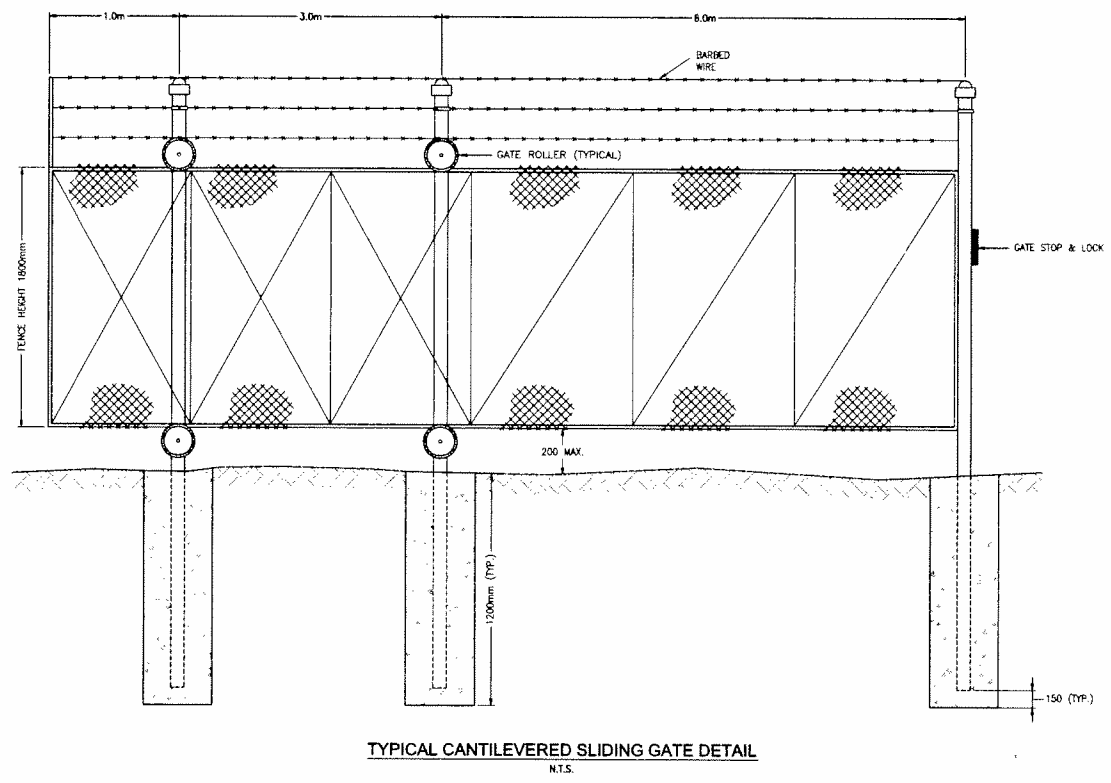
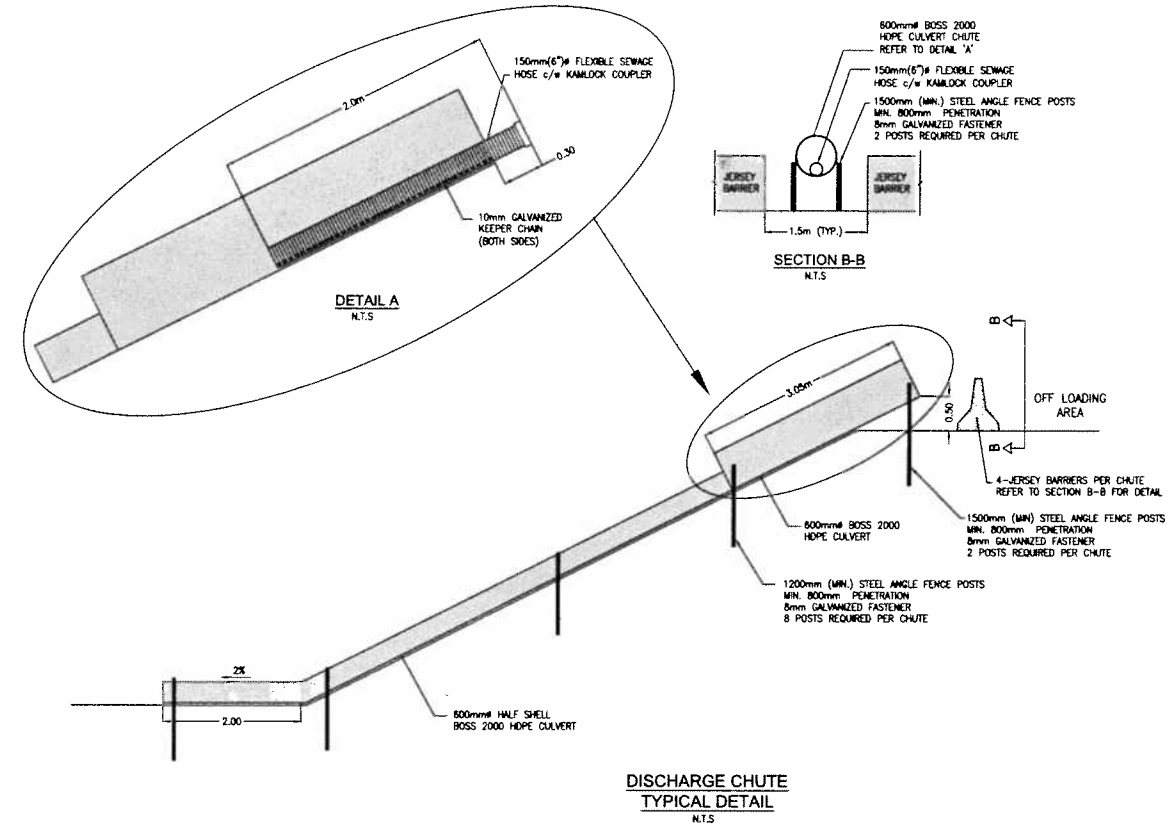
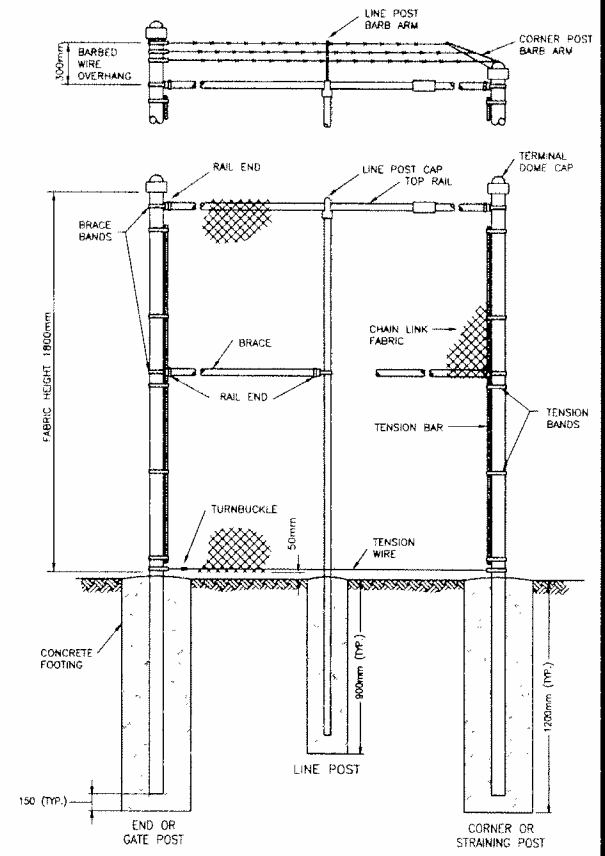

YWB

2007-200

Quest Engineering Group

1	ISSUED FOR REVIEW	APR 4 2007	VM
---	-------------------	------------	----

VISTA TEK LTD

803 WOOD ST. WHITEHORSE, YT, T1A 2G8
867-383-3468 867-383-3468 FAX

S.F.N. PROPOSED SEPTIC PIT

PELLY CROSSING

SITE DETAILS

DESIGNED BY	SCALE
VM	AS SHOWN
CHECKED BY	DATE
SB	30.03.07
PROJECT NO.	DATE
2007-200	2007-200
SHEET	PROJECT NO.
4	07200-4

MN07-071

MN07-071

EXHIBIT 1.2F